

Power Factor Controller

NOVAR 5, NOVAR 5+

Firmware v. 1.9

Operating Manual



CONTENTS

1.	DESCRIPTION.....	4
1.1	Novar 5 Basic Functions	4
1.2	Novar 5+ Additional Functions	4
1.3	Front Panel	5
1.4	Numeric Display	5
1.5	Indication LEDs	8
1.5.1	Output State Indications	8
1.5.2	Trend Indication.....	8
1.5.3	<i>Indication of Manual Mode</i>	9
1.5.4	Indication of Back Feeding	9
1.5.5	Alarm Indication.....	9
2.	INSTALLATION.....	10
2.1	Mechanical.....	10
2.2	Connection	10
2.2.1	Power Supply	10
2.2.2	Measurement Current	11
2.2.3	Error Indication.....	11
2.2.4	Output Relays.....	11
3.	PUTTING IN OPERATION	12
3.1	First Use.....	12
3.2	Automatic Connection Detection Process	12
3.3	Automatic Sectional Current Recognition Process.....	13
4.	OPERATION.....	15
4.1	Setup.....	15
4.1.1	Parameter Editing.....	15
4.1.1.1	Enable / Disable Parameter Editing	15
4.1.2	Parameter 01 – Target Power Factor.....	16
4.1.3	Parameter 02 – Regulation Time within Undercompensation	16
4.1.4	Parameter 03 – Regulation Time within Overcompensation	16
4.1.5	Parameters 12 – Metering Current Transformer Ratio.....	18
4.1.6	Parameter 14 – Reconnection Delay Time	18
4.1.7	Parameters 15,16 – Measurement Voltage Type and Connection	18
4.1.8	Parameter 17 – 6 th relay function	19
4.1.9	Parameter 20 – Automatic Sectional Current Recognition	19
4.1.10	Parameters 21, 22 – Switching Program and Smallest Capacitor Value (I_{MIN} , or C/k)	19

4.1.11	Parameter 23 – Number of Capacitors.....	20
4.1.12	Parameter 25 – Compensation Sections' Currents.....	21
4.1.13	Parameter 26 – Fixed Sections.....	21
4.1.14	Parameter 30 – Alarm Setting.....	21
4.1.14.1	Alarm Indication Function.....	22
4.1.14.2	Alarm Actuation Function.....	23
4.1.15	Parameter 31 – Capacitor Harmonic Load (CHL) Limit for Alarm Indication or Actuation.....	24
4.1.15.1	Capacitor Harmonic Load factor.....	24
4.1.16	Parameter 32 – Number of Switching Operations Limit for Alarm Indication or Actuation.....	26
4.1.17	Parameter 40 – Alarm Status.....	26
4.1.18	Parameters 41, 42, 43 – Extreme Mains Parameters Recorded.....	26
4.1.19	Parameter 44 – Number of Section Connections and Disconnections.....	26
4.1.20	Parameter 46 – Regulation Time.....	27
4.2	Section Value Accurization.....	27
4.3	Faulty Section Indication and Disablement.....	27
4.4	Regulation Interruption.....	28
4.5	Manual Mode.....	29
4.6	Manual Intervention in Regulation Process.....	29
4.7	Controller Initialization.....	29
4.8	Summary of Text Messages.....	31
5.	WIRING EXAMPLE.....	32
6.	TECHNICAL SPECIFICATIONS:.....	33
7.	MAINTENANCE, TROUBLESHOOTING.....	34

1. Description

1.1 *Novar 5 Basic Functions*

Novar 5 reactive power controllers are fully automatic instruments that allow optimum control of reactive power compensation. They were designed as economy version of more sophisticated type Novar 106 for non- and medium-demanding applications.

His precision evaluation of both root-mean-square (RMS) current and the power factor is achieved through digital processing of the values measured. The instrument calculates the fundamental harmonic component of the active currents using the FFT algorithm. Thus precise measurement and control are provided even if the current waveform is distorted by higher harmonic components.

The supply terminals also work as the measurement voltage input. The current measurement is designed for the nominal secondary winding current value of a current measuring transformer (CMT) 5A. The measuring inputs can be connected to the controller in any combination, that is any phase voltage and any phase current of the three-phase network.

Fully automatic installation is advantage of the instruments. The controller automatically detects both the mode of the current measured connection and the value of each compensation section connected. Entering these parameters manually is also possible. Any control section can be set as fixed, that is as constantly connected or constantly disconnected.

Controlling takes place in all four quadrants and its speed depends on both control deviation value and its polarization (overcompensation / undercompensation). Connecting and disconnecting power factor capacitors is carried out to achieve the optimum compensation condition with a single control step and minimum number of switching on or of the sections. At the same time, the instrument chooses the sections with regard to their even load and preferably connects those that have been disconnected for longest time and the remanent charge of which is thus minimum.

While controlling, the instrument continually checks the compensation sections. If a section's drop-out or value alteration is detected, the section is temporarily disabled at relevant setting. The section temporarily disabled is periodically tested, while control is in progress, and possibly enabled again.

The controller has six output relays. The 6th-relay operation is programmable to standard or alarm-signalling function.

1.2 *Novar 5+ Additional Functions*

Besides the functions described above Novar 5+ controller has following additional features :

- measuring and visualizing of Total Harmonic Distortion of voltage (THD), selected harmonic components and Capacitor Harmonic Load factor (CHL)
- alarm function for CHL factor added
- operational temperature range enlarged to -40 through $+60$ ° C

Therefore, Novar 5+ is convenient for use in more difficult environments both climatic and with worse quality of voltage.

History of Versions

version	date of release	note
1.6	04/1999	- basic version
1.7	01/2002	- optimized control algorithm
1.8	12/2002	- overvoltage alarm added
1.9	04/2005	- regulation time setting extension

1.3 Front Panel

The front panel consists of a numeric display, indication LEDs and a control keypad.

figure 1: front panel

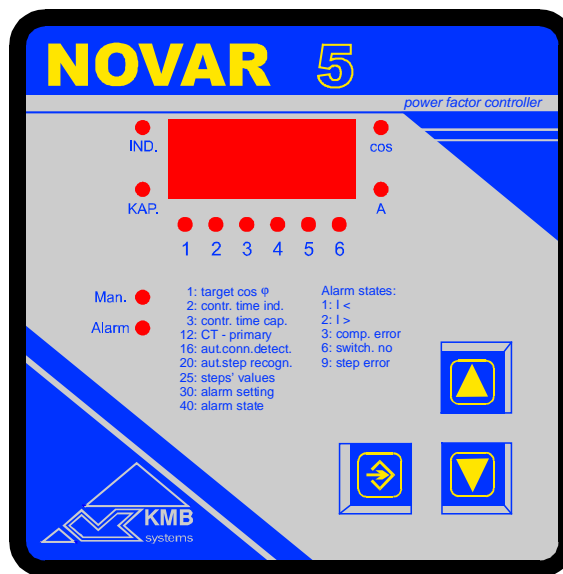

1.4 Numeric Display

Information shown on the numeric display can be divided into 3 main data groups:

- instantaneous mains values measured : power factor and current
- controller parameters
- test and error messages

While regulating, the controller displays one of the following instantaneous values:

- **COS** – power factor. The value corresponds to instantaneous ratio of active component to total current fundamental harmonic value in the mains. A positive value means inductive power factor, negative means capacitive power factor.
- **I_{eff}** – current effective value in the mains (including higher harmonic components) in amperes. If the value exceeds 999 A, only three upper digits are displayed and all decimal points are lit (for example, the **1.2.7.** means 1270 A)
- **U_{eff}** – voltage effective value in volts (Novar 5+ only). If decimal point is lit simultaneously, fundamental harmonic component frequency is 60 Hz.

If one of this values is displayed, appropriate LED (**COS**, **A** or **V**) is lit. At this state (if LED **Man.** is not lit simultaneously), the control process is in progress and the controller switches on and off the sections to reach target power factor.

Both instantaneous values and parameters of the controller are displayed at imaginary column – see figure 2. At the first two rows the instantaneous values of power factor and current are displayed, the parameters are displayed at the next rows. You can move up and down the column using the \uparrow , \downarrow buttons.

figure 2: display – structure

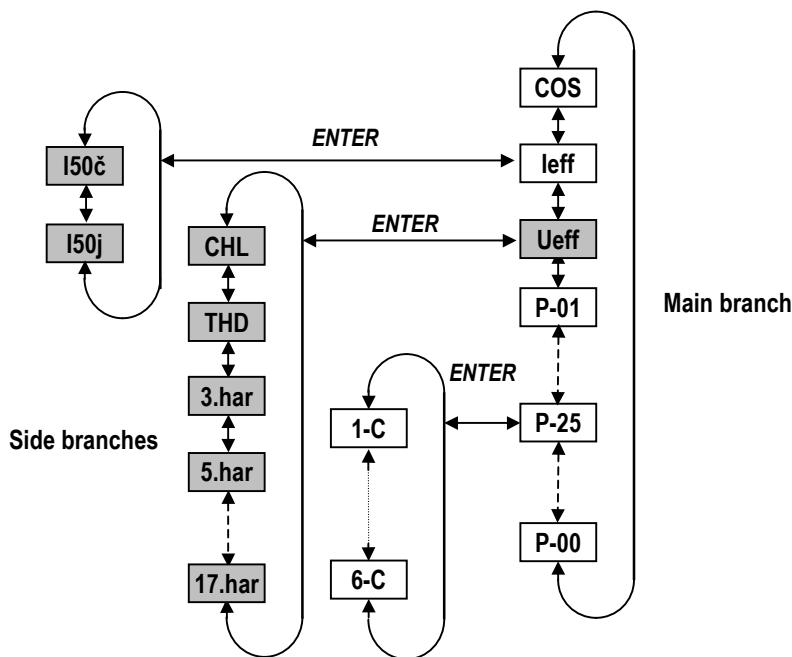

 ...marked windows at Novar 5+ only

If the I_{eff} value is displayed, you can switch to the current fundamental harmonic branch by pressing the **ENTER** button (Novar 5+ only). This branch contains two values:

- **150a** – active component of current fundamental harmonic. This value in amperes is indicated on display with **ACT** code (ACTive). Polarity of the value is indicated with LED **Feeding back** – when lit, active component is negative, i.e. energy flows from load to supply)
- **150r** – reactive component of current fundamental harmonic. This value in amperes is indicated on display with **REA** code (REActive). When this value is displayed, its polarity is indicated with LED **Feeding back** – when lit, reactive component is capacitive, otherwise inductive. Only in this single case LED **Feeding back** has this different meaning, in all other cases it has its standard meaning, i.e. polarity of active component of current fundamental harmonic.

Note: names I50a and I50r are derived from the frequency of fundamental harmonic component, which is usually 50 Hz. In systems with nominal frequency 60 Hz, the fundamental harmonic component has frequency 60 Hz, of course.

You can again move up and down the branch using the \uparrow , \downarrow buttons. To get back to the main branch of instantaneous values press button **ENTER**.

You can switch to the voltage harmonic distortion branch while voltage is shown by pressing button **ENTER** (Novar 5+ only). The branch contains following values :

- **CHL** – capacitor harmonic load factor in percents (for detailed definition see parameter 31 description)
- **THD** – level of voltage total harmonic distortion in the mains — this percental value is calculated from the measured curve using the FFT algorithm and it tells the ratio of content of voltage higher harmonic component up to the 19th harmonic to voltage fundamental harmonic level
- **H3...H17** – value of selected voltage harmonics as percentage of the fundamental harmonic

You can switch among **CHL**, **THD** and all selected harmonic components (3rd, 5th, 7th, 11th, 13th, and 17th) by pressing the \uparrow , \downarrow . These harmonic components were selected since they represent the most usual cases of distortion and their values are usually the highest when compared with the others. To get back to the main branch of instantaneous values press button **ENTER** again.

When any of parameter is displayed, all of LEDs **COS**, **A** and **V** are dark and control process is temporarily frozen. (exception: parameter 46 - see description further below).

By pressing the \uparrow , \downarrow , parameters can be displayed. First the parameter number shows momentarily and then its value does. The parameter number flashes momentarily every five seconds for better orientation.

The parameters can be divided into three main groups:

- Parameters determining controller functions. These parameters can be set to direct the regulation process. There are power factor required, regulation period, reconnection delay time, etc.
- Parameters indicating controller's current state. This is a current state of alarm (parameter 40) and regulation time state (parameter 46). These parameters' values are set by the controller and they are used to identify nonstandard or error conditions closely and monitor progress of the regulation process in detail.
- Parameters registered during control process. They are extreme measured values (minimal power factor, maximal CHL and harmonic levels – at Novar 5+ only) and number of connections of each compensation section. These values are set by the controller and the operator can only reset them.

The parameters are organized by ordinal number in the main branch – see figure 2. Some of the parameters (parameter 25 – sectional current, 26 – fixed sections, 30 – alarm setting, 40 – state of alarm, 43 – maximal harmonic levels, 44 – number of sections connected) are located on side branches for easier navigation. You can switch to a side branch with selected parameters by pressing button **ENTER** and switch back to the main branch in the same way.

Side branch parameter displayed can be identified from a dash between the parameter number and value. For example: in the main branch, while showing parameter 26 (fixed sections), you will see **1** **└** (section 1 is regulating capacitive); if you want to display conditions of the other sections, you need

to switch display to the side branch by pressing button **ENTER**; the display will change to **I-C** and now you can move up and down through all sections' values on the side branch. Pressing button **ENTER** again returns display to the main branch (the dash disappears).

When any of parameter is displayed, control process is temporarily frozen. The controller gets back to the control mode automatically in about 30 seconds from the last press of button (exception: parameter 46 - see description further below) – simultaneously, temporarily frozen control process is released again.

Exception: In the manual mode (**Man.** LED is flashing), the parameter values can not be viewed. Instead of this, instantaneous output values are displayed - see description further below.

A test or error message pops up in place of an instantaneous power factor value in some situations. Each message are described further below in more detail. In these situations, when the value shown does not represent instantaneous power factor, the **COS** LED flashes.

1.5 Indication LEDs

Besides the numeric display and adjacent LEDs, **COS**, **A** and **V**, the front panel has some more indication LEDs.

1.5.1 Output State Indications

The array of LEDs at the top right part of the front panel show the current state of output relays. Each LED is assigned a number from 1 to 6, and if lit they indicate closed contacts of corresponding output relay.

If a LED is flashing, it means the controller wants to switch on the output, but it has to wait for the delay time to elapse. The corresponding output relay is open and it will be closed as soon as the reconnection delay time has elapsed.

An exception is the power-up display test to check correct operation of all display elements. In this test the display shows **TST** and all indication LEDs go on and off one by one. All output relays stay open while the test is running.

1.5.2 Trend Indication

These LEDs show the magnitude of deviation of the true instantaneous reactive power in the mains from optimum reactive power value which would correspond to the set value of required power factor.

If the deviation is smaller than a half of the reactive power value of the smallest capacitor, both LEDs are dark. If the deviation is greater than a half of, but smaller than, the reactive power value of the smallest capacitor, the corresponding LED flashes — if lagging (undercompensation), the **IND** LED flashes; if leading (overcompensation), the **CAP** LED flashes. If the deviation exceeds the value of the smallest capacitor, the corresponding LED is permanently lit.

Exceptions to these LEDs' meanings are the following situations:

- measurement U and I method of connection is not defined (parameter 16)
- process of automatic connection detection is in progress
- process of automatic detection of sections' currents is in progress

If the method of connection is not defined, both LEDs flash; they are dark in the other two situations.

1.5.3 Indication of Manual Mode

Flashing **Man.** LED indicates that the controller is in the manual mode. The controller's regulating function is disabled.

If this LED is dark and one of instantaneous values (power factor or current) is displayed, the controller is in its standard regulating mode or it is carrying out automatic connection detection or automatic recognition of output currents.

1.5.4 Indication of Back Feeding

Only Novar 5+ controllers are equipped with this LED. If the controller knows of the method of connection (measurement voltage and current), that is if the process of automatic connection detection has been completed successfully or the method of connection has been entered manually, the **Feeding Back** LED indicates the power transmission direction. If it is dark, the power is flowing from the assumed power supply to the appliance. If the LED is flashing, the power is flowing in the opposite direction.

Exception : When current reactive component of fundamental harmonic is displayed, the LED indicates polarity of this value : when lit, reactive component is capacitive, otherwise inductive. Only in this single case LED **Feeding back** has this different meaning, in all other cases it has its standard meaning as described above.

1.5.5 Alarm Indication

Non standard states can be indicated with both **Alarm** LED and the 6th relay (in case it is not used as control section only).

When alarm state is active, the **Alarm** LED flashes. For signalling this state with the 6th relay, appropriate function of the output must be set (see description of parameter 17).

Detailed alarm state setting and evaluation can be found at description of parameter 30.

2. Installation

2.1 Mechanical

The instrument is built in a plastic box to be mounted in a switchboard panel. The installation opening dimensions are to be 92 x 92 mm. The instrument's position is fixed through enclosed locks.

2.2 Connection

To connect the controller there is connector with screw-on terminal in the back wall. Configuration of signals on the connector is illustrated in figure 3.

Examples of controller connections are shown in a separate chapter.

figure 3 : Novar 5 controller – connector

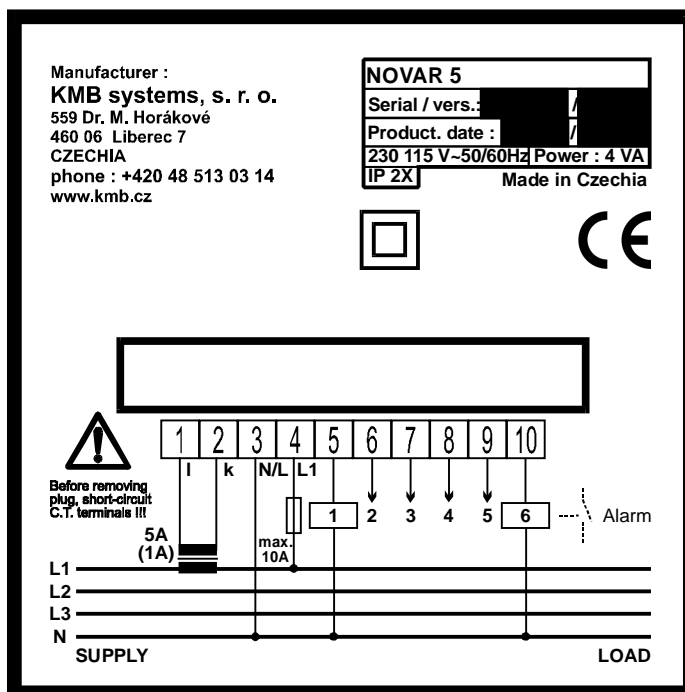

Maxim cross section area of connection wires is 2.5 square milimeters.

2.2.1 Power Supply

The controller requires supply voltage at nominal value 230 or 115 V AC (according the device type), 50/60Hz, for its operation while the power requirement is maximum 4 VA. The power supply voltage is used as measurement voltage.

The supply voltage connects to terminals 4 (**L1**) and 3 (**N/L**). The supply voltage is not internally protected - external fuse or breaker is required. Power supply terminal 4 (**L1**) is internally connected to the common pole of output relays. It is necessary to dimension the power supply protection considering output circuit breakers' power as well.

Since the instrument does not have its own power switch, you must include a disconnecting device in the power supply circuit (switch — see installation diagram). It must be located right at the instrument and easily accessible by the operator. The disconnecting device must be marked as such. A circuit breaker for nominal current of 6 amp makes a suitable disconnecting device, its function and positions, however, must be clearly marked (symbols “0” and “1” in accordance with EN 610 10–1).

2.2.2 Measurement Current

Metering current transformer outputs connect to terminals 2 (**k**) and 1 (**I**). A metering current transformer of nominal output current 5A is recommended. The connector features a screw lock to prevent accidental pull-out.

2.2.3 Error Indication

The instrument has an auxiliary Alarm relay to indicate nonstandard conditions. This relay's contact goes to terminals 17 and 18. It can be loaded with current 4 A at 250 V AC.

2.2.4 Output Relays

The instrument has 6 output relays. The relays' contacts go to terminals 5 through 10. Relays' common contacts are internally connected to power supply terminal 4 (**L1**) — when an output relay contact closes, power supply voltage appears at the corresponding output terminal.

The relays' output contacts are wired with varistors. They can be loaded with current 4 A at 250 V AC.

If the 6th relay is used for alarm signalling, note that even at disclosed contact the supply voltage potential is present due to protecting varistor (impedance of several MOhms). Therefore auxiliary external relay is recommended for this function and its potential-free contact can be used for the signalling.

In installation there may be a need to test function of each regulation section by manual connection and disconnection — this can be done in the *Manual* mode or using *Manual intervention in regulation process* (see further below).

3. Putting in Operation

3.1 First Use

The controller comes preset to default values as shown in table 1.

On power-up a display test runs first. The display momentarily shows

- type of controller (e.g. ***MOS***)
- firmware version (e.g. ***1.8***)
- type of measurement voltage set (***U=P*** or ***U=L***)
- preset function of the 6th relay (***6=C*** , ***6=A*** or ***6=R*** .)

If the measurement voltage connection is correct and the measurement current is sufficient (that is the current metering transformer current is higher than 0.05 A), the automatic connection detection process starts.

If no measurement voltage is detected, ***U=0*** will flash on the display, if too low measurement current is detected, ***I=0*** will .

3.2 Automatic Connection Detection Process

The controller's default measurement voltage and current connection parameters are set as follows:

- type of measurement voltage set to phase voltage (parameter 15)
- method of connection of U and I not defined (parameter 16)

If the method of connection is not defined, the controller can not evaluate instantaneous power factor and this condition is indicated by both trend LEDs flashing simultaneously. In such a case the controller carries out automatic connection detection.

For the controller to be able to carry out this process of automatic connection detection, the following conditions must be met:

- controller operation is not disabled (i.e. the ***Man.*** LED is dark)
- controller is in regulation mode, i.e. one of instantaneous values (power factor , current or voltage) is displayed (appropriate LED is lit)
- measurement current is sufficient

If meeting these conditions, the controller starts the automatic connection detection process.

The process may have up to seven steps. The controller makes four measuring attempts in each step in which it consecutively connects and disconnects sections 1 through 4. It at the same time assumes that power factor capacitors are connected to at least two of the sections. The two following messages are shown one after another in each measurement attempt on the numeric display:

1. step number in format ***APX*** (Automatic Phase detection, x... attempt number)
2. attempt result, e.g. ***I=0*** (see table 2 of connection methods)

If the controller measures identical values repeatedly in each attempt, it considers the connection detected and quits carrying out further steps. If the measurement results are different from each other in a particular step, the controller carries out another measurement step.

The following conditions must be met for successful connection detection:

- type of measurement voltage is set correctly (phase or line voltage – parameters 15)
- at least two power factor capacitors are connected to sections 1 through 4

Type of connection detected is shown on the numeric display for a moment after successful completion of the automatic connection detection process, the true power factor value in the mains, and thereafter the instrument starts the regulation process or it starts the section recognition process (see further below).

If the automatic connection detection process is not completed successfully, the numeric display shows flashing $P = 0$. It is, in such a case, necessary to enter the connection type manually or to re-enter --- (= not defined) in editing parameter 16 and thus restart the automatic connection detection process. Otherwise the controller changes over to a waiting mode and it repeats the automatic connection detection process in 15 minutes automatically.

The automatic connection detection process can be interrupted any time by switching the numeric display to any of parameters , that is by pressing buttons \uparrow , \downarrow . The automatic connection detection process will start again from scratch on return to display any of instantaneous values.

3.3 Automatic Sectional Current Recognition Process

The controllers come as standard with enabled function of automatic sectional current recognition (parameter 20 set to 1). At this setting the controller carries out the automatic sectional current detection process on **every** controller power-up (connection of power supply voltage). The process can also be started without interrupting the power supply voltage connection, by editing parameter 20 to value 1 or by controller initialisation (see further below).

For the controller to be able to start the process of automatic sectional current recognition, the following conditions must be met:

- controller operation is not disabled (i.e. the **Man.** LED is dark)
- controller is in regulation mode, i.e. one of instantaneous values (power factor, current or voltage) is displayed (appropriate LED is lit)
- measurement current is sufficient
- connection mode of measurement U and I is defined (parameter 16)

If these conditions are met, the controller starts the automatic sectional current recognition process.

The process may have three or six steps. The controller consecutively connects and disconnects each output in each step (that is 5 or 6 outputs, according parameter 17 setting). While doing that it measures the effect of connection and disconnection on total reactive current in the mains. From the values measured the current of each section is determined.

The following messages are shown one after another in each measurement attempt on the numeric display:

1. step number in format **ACX** (x... step number)

2. sectional current measured in amperes; if the metering current transformer nominal primary side current has been entered (parameter 12), sectional current in the mains is shown (that is the metering current transformer primary current); if the metering current transformer primary side is not defined, sectional current in the metering current transformer's secondary winding is shown

If the controller does not succeed in determining a section's value, it does not show it. This condition occurs if reactive current value in the mains fluctuates considerably due to changes in load.

After carrying out three steps, evaluation is carried out. If each measurement in the steps carried out provide sufficiently stable results, the detection process is completed. Otherwise the controller carries out three more steps. It puts an interval of approximately 30 seconds between each three steps.

A requirement for successful detection of current in each section is sufficiently stable condition of the mains – while connecting or disconnecting a section, the reactive load current must not change by a value which is comparable with, or even greater than, the reactive current value of the section under test. Otherwise the measurement result is unsuccessful.

On successful completion of automatic section detection process the controller checks whether at least one capacitive section has been detected and if so, it starts regulation. Otherwise the controller goes to the waiting mode and after 15 minutes it starts the automatic sectional current recognition process again.

Each section value recognized can be checked in side parameter branch 25. A positive current value means a capacitive section, negative value means inductive section. If the value could not be recognized, “ --- ” is shown. Each value recognized can be edited manually.

Recommendation :

*After checking values recognized it is recommended at this phase to switch parameter 20 to 0 (**ACD**). If switching automatic recognition process off, contingent unsuccessful results of recognition process after accidental power supply drop-out (due to great load and reactive current fluctuations after power recovery) will be avoided.*

If the automatic sectional current recognition process can not be completed successfully or none of the sections recognized is capacitive, flashing **C = 0** is shown on the numeric display and the **Alarm** signal is activated at the same time. In such a case it is necessary to enter each section's value manually (see description further below) or by editing parameter 20 enter value **1** (= carry out automatic recognition) and thus force another start of the automatic sectional current recognition process.

The automatic sectional current recognition process can be stopped any time by switching the display mode to any of parameters or by pressing button **ENTER**. On return to one of instantaneous values display the automatic sectional current recognition process will be started from the beginning again.

4. Operation

4.1 Setup

To achieve optimum regulation in accordance with character of the load regulated the controller has a number of parameters that govern its operation. table 1 shows a list of the parameters. The following chapters describe each parameter, its meaning and how it can be edited.

4.1.1 Parameter Editing

The controller's parameters are set to default values, which are shown in table 1, when shipped.

To achieve optimum regulation results, it is sometime necessary to change some of the values in correspondence with particular requirements; in the other situations it is at least necessary to enter the measurement voltage type (phase or line) and 6th relay function (parameter 17) in installation.

To prevent unqualified operation, controller parameter editing can be disabled in which case it requires entering password prior to editing (see further below). If parameter editing is enabled, you should proceed as follows:

1. Find parameter you want to edit by pressing the \uparrow , \downarrow buttons repeatedly.
2. Press button **ENTER** and hold it down until the display starts flashing.
3. Release button **ENTER** and set the value desired with the \uparrow , \downarrow buttons. Some values can be incremented or decremented continuously by holding down the \uparrow or \downarrow button.
4. When the value desired has been reached, press button **ENTER**. The value set will be saved in the controller's memory, the display stops flashing and editing is thus complete.

4.1.1.1 Enable / Disable Parameter Editing

When shipped, the controller is in the enabled status, that is the parameters can be edited freely on power supply voltage connection without prior password entry. After being put in operation parameter editing can be disabled to protect the controller against unauthorized changes in operation this way.

To see if editing is disabled or enabled check parameter 00. It can contain the following:

P = - password not yet entered, parameter editing disabled

P = Y password entered correctly, parameters can be edited

The edit enable / disable status is saved in the controller even after power outage.

If the password has not been entered correctly, the instrument's parameters can not be changed.

Password is entered in a similar way to that of controller parameter editing:

1. Switch controller to display parameter 00 (controller must not be in the manual mode).
2. Press button **ENTER** and hold it down until the last character on the display starts flashing. A digit between 0 and 9 will be shown on the last digit position. As an example you can imagine 5 is displayed so the display shows **P = 5** with the **5** flashing.
3. Press the following sequence: \downarrow , \uparrow , \uparrow , \downarrow . If **5** was shown as the last display digit, it would change to **4, 5, 6, 5** so the same value is shown at the end as at the beginning.
4. Press button **ENTER**. The display will show **P = Y**, indicating correct password entry and enabled parameter editing.

The digit shown while entering the password is random generated by the controller and it is not important for password correctness (it is there only to confuse). Only the sequence of buttons pressed is important.

After correct password entry, parameter edit mode is enabled until it gets disabled by the operator. The parameter edit enable or disable conditioned is retained in the instrument even on power off.

Parameter edit disable mode is switched to on (intentional) pressing buttons different from the correct password entry sequence.

4.1.2 Parameter 01 – Target Power Factor

The value of target power factor can be set in the range from 0.80 lag to 0.80 lead.

4.1.3 Parameter 02 – Regulation Time within Undercompensation

The value can be set in range from 5 seconds to 20 minutes : 0.05 - 0.10 - 0.15 - 0.20 - 0.30 - 1.0 - 2.0 - 3.0 - 5.0 - 10.0 - 20.0 (value in front of decimal point specifies minutes, the one behind decimal point specifies seconds). The value set determines the frequency of regulation interventions under the following conditions:

- instantaneous power factor is more inductive than the one required – undercompensated
- the difference between reactive current instantaneous value in the mains and optimum value, which corresponds to the power factor required setting (= control deviation), is just equal to the smallest capacitive section current (C/k)

If the parameter value is set to say 3.0 and the above mentioned conditions are met in the mains, the controller calculates optimum compensation and carries out regulation intervention every 3 minutes.

The time mentioned gets shorter in proportion to the instantaneous control deviation. If regulation time without preceding character "L" is set, it gets shorter as square of control deviation over the smallest capacitive section value (C/k). If the regulation time with preceding character "L" is set, it gets shorter proportionally as the ratio ("L" = Linear, causes slower reaction to great deviations). Rising control deviation can decrease this value down to the minimum regulation time of 5 seconds.

On the contrary, if the control deviation is smaller than the smallest capacitive section current (C/k), regulation time gets twice as long. If the control deviation falls further under half of the smallest capacitive section current value (C/k), no regulation intervention takes place.

4.1.4 Parameter 03 – Regulation Time within Overcompensation

The value set determines frequency of regulation interventions, very much like in parameter 02 described above. There is a difference though: it only applies if the instantaneous power factor is more capacitive than that required, that is it is overcompensated.

The regulation time's effect in proportion to control deviation magnitude is the same as with parameter 02 described above.

table 1: Controller Parameters

#	meaning	setting range	step	default	note
1	target power factor	0.80 lag to 0.80 lead	0.01	0.98 lag	
2	regulation time when undercompensated	5,10,15, 20, 30, 60, 120, 180, 300, 600, 1200 seconds	-	180	without "L" : square decreasing with "L" : linear decreasing
3	regulation time when overcompensated	5,10,15, 20, 30, 60, 120, 180, 300, 600, 1200 seconds	-	30	without "L" : square decreasing with "L" : linear decreasing
12	C.T. primary side nominal value	5 ÷ 9950 A	5	none	metering current transformer secondary side nominal value 5A supposed
14	reconnection delay time	5,10, 20, 30, 60, 120, 300, 600, 1200 sec.	-	20	
15	measurement voltage type – phase (phase-neutral) or line (phase-phase)	P – L	-	P	This parameter's correct setting is essential for automatic connection detection process.
16	method of connection of U and I	6 combinations	-	none	see parameter description
20	automatic sectional current recognition	0 (no) - 1 (yes)	-	1 (yes)	Automatic sectional current detection takes place on switching this parameter from 0 to 1 or on controller power-up while value 1 is set here.
21	connecting program	12 typical combinations	-	none	0 means individual section setting. Not shown if automatic section recognition is enabled.
22	smallest capacitor current (C/k value calculated for C.T. primary side)	(0.05 ÷ 2 A) x metering current transformer ratio	0.01	none	Value on metering current transformer's primary side – if its primary nominal value has not been entered, secondary side current is shown. Not shown if automatic section recognition is enabled.
23	number of capacitors	5 (6)	-	5 (6)	Not shown if automatic section recognition is enabled.
25	sectional current	(0.05÷8A) xC.T. ratio	0.01	none	positive for capacitive sections (lead), negative for chokes (lag)
26	fixed sections	regulated / 0 / 1	-	all regulated	
27	limit power factor for regulation by choke	0.80 lag to 0.90 lead	0.01	none	No regulation by chokes takes place unless this parameter is specified.
30	alarm setting	0 / indication only / actuation only / indication and actuation	-	ind. & act. if undercurrent, voltage signal absence or section error	list of conditions: 1... undercurrent 7... overvoltage 2... overcurrent 8... feeding back 3... compensation error 9... section error 4... voltage signal absence 5... harmonic distortion 6... number of connections exceeded
31	CHL limit (for alarm)	0.5 ÷ 500 %	0.5	40	Novar 5+ only not shown unless alarm from CHL limit set
32	limit number of switch. operations (alarm)	10,000÷2,000,000	10,000	1,000,000	not shown unless alarm from limit number of switching operations set
40	alarm instantaneous condition				Indicates current state of alarm.
41	minimum power factor recorded				Novar 5+ only in operation from load 10 % up
42	maximum CHL recorded				Novar 5+ only
43	maximum value of harmonics (3-5-7-11-13-17 th)				Novar 5+ only
44	number of section connections (in thousands)				display range 0.001 to 9999
46	regulation time instantaneous condition				time until next regulation intervention in seconds
00	edit enabled (password)	- (no) / Y(yes)	-	Y	see Enable / Disable Parameter Editing

4.1.5 Parameters 12 – Metering Current Transformer Ratio

You can set metering current transformer nominal primary value in amperes using parameter 12. The setting range is from 5 to 9,950. There is supposed nominal secondary value is 5 amperes.

This parameter (12) is not defined (--- shown) by default. With this setting, all values that are current-related, that is measured values of instantaneous current and further the C/k value (parameter 22) and currents in each section (parameter 25), are shown in the magnitude to which they are transformed at the metering current transformer secondary side. The parameter's value set does not affect the controller's regulation operation, it only affects displayed values that are related to current.

4.1.6 Parameter 14 – Reconnection Delay Time

It is used to ensure sufficient discharge of a capacitive section prior to reconnection. It can be set in range 5 seconds to 20 minutes to one of the values 0.05 - 0.10 – 0.20 – 0.30 – 1.0 – 2.0 – 5.0 – 10.0 – 20.0. Format is the same as at parameter 2.

4.1.7 Parameters 15,16 – Measurement Voltage Type and Connection

Parameter 15 determines if the measurement voltage connected is phase voltage (phase-neutral, $U=P$, default value) or line voltage (phase-phase, $U=L$).

Connection type parameter must definitely be set correctly in installation, even if automatic connection detection process is assumed to take place. Otherwise the power factor measured will be evaluated with errors!

The connection type parameter (15) value set will be kept even on controller *initialisation* (see description further below).

Parameter 16 determines the method of measurement voltage connection with respect to measurement current, that is between which phases or neutral wire the measurement voltage is connected. It is assumed that the metering current transformer is in phase 1 and its orientation (terminals k, l) corresponds to real orientation supply–appliance. The method of connection is specified as one of six combinations as in table 2.

table 2: measurement voltage connection

phase voltage $U=P$		line voltage $U=L$	
#	connection	#	connection
1	$L1-0$	1	$L1-L2$
2	$L2-0$	2	$L2-L3$
3	$L3-0$	3	$L3-L1$
4	$0-L1$	4	$L2-L1$
5	$0-L2$	5	$L3-L2$
6	$0-L3$	6	$L1-L3$

Notes:

- It is assumed that the metering current transformer is in phase 1 and its orientation (terminals k, l) corresponds to real orientation supply–appliance.
- The method of connection is shown as x–y where x represents the phase connected to controller's terminal **L1** and y represents the phase connected to controller's terminal **N/L** (0 represents the neutral wire).

If the connection method value is entered as not specified (--- value), the automatic connection detection process is started. If the type of connection (phase or line, parameter 15) is changed, the method of connection (parameter 16) is automatically set to undefined value.

4.1.8 Parameter 17 – 6th relay function

The 6th relay behaviour can be programmed to one of two functions :

- alarm function (set by default)
- standard control section output

The parameter can be set to one of three following values :

- **5-C** the 6th relay is used as standard section control relay
- **5-A** the 6th relay is used for alarm signalling – it is **closed** in alarm active state
- **5-A.** (with dec. point lit) 6th relay is used for alarm signalling – it is **open** in alarm active state

If alarm function of the 6th relay is set, non standard states are indicated not only with the **Alarm** LED, but with appropriate state of the 6th relay as well.

The parameter value set will be kept even on controller *initialisation* (see description further below).

4.1.9 Parameter 20 – Automatic Sectional Current Recognition

The controllers are shipped with default setting of enabled automatic sectional current recognition (parameter 20 set to 1, **AC1**). With this setting the controller carries out the automatic sectional current recognition process **always** on controller power-up (introduction of power supply voltage).

The process can also be started without interrupting power supply voltage, by editing parameter 20 to value **1** or by controller initialisation (see further below).

If automatic section detection is set, it makes no sense to set parameters 21 through 24, therefore these parameters are not shown.

Automatic sectional current recognition can be disabled by setting parameter 20 to **0**. In such a case sections' values must be entered using parameters 21 through 24.

4.1.10 Parameters 21, 22 – Switching Program and Smallest Capacitor Value (I_{MIN} , or C/k)

If automatic sectional current recognition is disabled, you can enter the value of each section using these parameters.

Parameter 21 specifies the switching program which determines the ratio of values of individual capacitive sections. One of preset combinations can be selected as shown in table 3.

The capacitors must be connected to the controller's outputs in the order corresponding to the switching program selected so that the smallest value capacitor is at output 1. The number of capacitors connected must be entered in parameter 23. If this number is greater than 5, the controller assumes that values of sections 6 and higher are equal to section 5 value.

If none of the preset combinations corresponds to the arrangement required, any value of each section can be entered by editing parameter 25. In such a case the switching program parameter (21) is automatically set to ---, which indicates *individual switching program*. In this case parameter 22 misses its purpose so it is not shown.

table 3: switching program

#	combination	displayed	#	combination	displayed
1	1:1:1:1:1	1111	7	1:2:2:2:2	1222
2	1:1:2:2:2	1122	8	1:2:3:3:3	1233
3	1:1:2:2:4	11224	9	1:2:3:4:4	1234
4	1:1:2:3:3	1123	10	1:2:3:6:6	1236
5	1:1:2:4:4	1124	11	1:2:4:4:4	1244
6	1:1:2:4:8	11248	12	1:2:4:8:8	1248

If the switching program is set to one of the values shown in table 3, you still have to enter the smallest capacitor current, I_{MIN} (corresponding the value 1, parameter 22). This value is displayed in amperes and is either equal to the capacitor's real current in the mains (if the current transformer's nominal primary value has been specified) or equal to current at the current transformer's secondary side (in the other case) – then the value is what is generally known as C/k constant.

You can determine the smallest capacitor's current using the formula

$$I_{MIN} = Q_{MIN} / (1,73 \times U_L) [A, VAr, V]$$

I_{MIN} smallest section's current in amperes

Q_{MIN} smallest section's power in volt-amperes reactive

U_L line voltage in volts (for example 400 V)

The following table shows currents for most used compensation capacitors:

table 4: capacitor's current (for $U_L = 400V$)

Q [kVAr]	2	3.15	4	5	6.25	8	10	12.5
I [A]	2.9	4.6	5.8	7.2	9.0	11.6	14.5	18.1
Q [kVAr]	15	20	25	30	40	50	60	100
I [A]	21.7	28.9	36.1	43.4	57.8	72.3	86.7	144.5

If the metering current transformer's nominal primary value has not been specified, it is necessary to enter the C/k value rather than the smallest capacitor current. You can obtain this value as a ratio of the smallest capacitor current and the metering current transformer ratio. C/k value can be set in the range between 0.05 and 2 A.

If the metering current transformer's nominal primary value has been specified, the smallest capacitor current is to be entered, I_{MIN} (equal to C/k value multiplied by metering current transformer ratio).

4.1.11 Parameter 23 – Number of Capacitors

If entering capacitors' currents manually using the switching program and smallest capacitor current (parameters 21, 22), it is also necessary to enter the number of capacitors connected – parameter 23. The value can be set within a range 1 through the controller's number of outputs, which is 5 or 6 (depending on parameter 17 setting).

If using a smaller number of capacitors than the type of controller allows, it is necessary to connect the capacitors to outputs starting with output 1 (that is the unconnected outputs will be those with the highest ordinal numbers).

4.1.12 Parameter 25 – Compensation Sections' Currents

Current of each compensation output can be edited in the side branch of this parameter if necessary.

The currents are shown in amperes. They are equal to either real current of the compensation section (capacitor or choke) in the mains (if the metering current transformer's nominal primary value has been specified) or the metering current transformer's secondary value (in the other case). Capacitive sections are shown as positive, inductive sections as negative. If a section's current is not known (for example because of successful completion of the automatic section recognition process), the --- value is shown. In such a case, as well as in the case of section current zero value, the controller does not use the corresponding regulation output.

If the section current values is greater than 999 amperes, only three upper digits of the value are displayed – this state is indicated with all three decimal points lit.

The controller is shipped with default setting of automatic section recognition enabled (parameter 20 set to 1). The automatic sectional current recognition process is started on introducing the power supply voltage and after it has finished you can check or edit the recognized currents in the side branch of parameter 25.

Each sectional current can be changed even if they have been entered manually using the switching program and smallest capacitor current (parameters 21, 22).

If a section's value is shown with a flashing decimal point (or points), it means:

- decimal point flashing **slowly** (about once a second), the section has not been accurized yet – see description of the mechanism to accurize sections in a relevant chapter further below
- decimal point flashing **fast** (about three times a second), the section has been disabled and the controller is not using it – see description of the mechanism to section disablement in a relevant chapter further below

4.1.13 Parameter 26 – Fixed Sections

Any controller output can be set as fixed. In such a case the output is permanently connected or disconnected and the controller does not use it for regulation. A fixed output **remains in a prespecified condition** (that is connected or disconnected) with the following exceptions:

- the controller is switched to the manual mode
- a selected nonstandard condition occurs while the alarm's corresponding actuation function has been set (for details see alarm description further below)

By default all controller's outputs are set as regulating, not fixed. In such a case they are shown for example as follows:

1-ℒ... output 1 is regulating, that means a control section is connected to it

Each section's value can be set to 1 or 0 — in that case 1-1 or 1-0, respectively, is shown and the corresponding output becomes a fixed one – it will be permanently connected or disconnected.

4.1.14 Parameter 30 – Alarm Setting

Novar line controllers feature two alarm type functions that are independent of each other:

- alarm indication function
- alarm actuation function

4.1.14.1 Alarm Indication Function

In order to indicate nonstandard regulation conditions the instruments feature an **Alarm** LED on the front panel. If required, the 6th relay contact at a connector on the rear panel can be used.

Indication of a nonstandard condition occurrence shows as flashing **Alarm** LED and possibly closed or open 6th relay contact (according parameter 17 setting). In standard condition this LED is dark and the relay contact is in appropriate inactive state.

table 5: Alarm – indication

#	condition	description	minimum delay activation / deact.
1	undercurrent	current at metering current transformer's secondary under minimum measurement current	5 / 5 seconds
2	overcurrent	current at metering current transformer's secondary over nominal value (5 A)	5 / 5 seconds
3	compensation error	power factor out of range 0.9lag ÷ 1.00 – working from load 10 % up	15 / 7.5 minutes
4	voltage failure	measurement voltage not detected	5 / 5 seconds
5	harmonic distortion	CHL limit setting exceeded (Novar 5+ only)	1 / 1 minute
6	number of switching operations exceeded	number of connecting and disconnecting a section has exceeded a limit setting	immediately
7	overvoltage	voltage over 110 % of nominal value (230/115 V)	1 / 1 minute
8	feeding back	power flow from appliance to source detected (Novar 5+ only)	5 / 2.5 minutes
9	section error	permanently wrong section value detected in regulation (usually section failure)	5 connections + 5 disconnections

Note: Bold type conditions above are set by default.

Nonstandard condition mentioned above, at which alarm should be indicated, can be specified in the side branch of parameter 30. Any of the eight conditions shown in table 5 can start the alarm indication.

Alarm indication from any nonstandard condition can be selected by editing such a condition in the side branch of parameter 30. The settings can take 4 different values:

1. **I-0**... condition 1 (undercurrent) is not signalled (neither does it trigger actuation – see description further below)
2. **I-5**... condition 1 (undercurrent) is signalled (but it does not trigger actuation)
3. **I-A**... condition 1 (undercurrent) is not signalled (but it triggers actuation)
4. **I-2**... condition 1 (undercurrent) is signalled (and it triggers actuation)

Alarm signalling can be set for any other condition in the same manner as shown for condition 1 in the above example. For some conditions alarm actuation can be specified besides indication (see description further below).

Alarm indication can be triggered by one or a combination of some conditions set. Alarm indication will start after the condition lasts continuously for the time specified in table 5 as 1st value ; 2nd value (behind „/“) defines elapse time to stop alarm indication after the condition would disappear. The condition that has triggered alarm indication can then be checked in alarm status (in the side branch of parameter 40).

Unlike the alarm actuation function described below, the alarm indication function setting has no effect on the instrument's regulation process.

Besides conditions mentioned above, alarm indication will also be triggered by a condition when at least one nonzero capacitive section has not been specified (when entering sectional currents manually) or identified (in automatic section recognition process). In this condition flashing $\mathcal{L} = \mathcal{O}$ is shown on the numeric display.

Note : Numbering of alarm states corresponds with the ones of the Novar 1xx/2xx controller line. As the Novar 5 controllers don't evaluate all of the nonstandard states as the Novar 1xx/2xx controllers do, this states are missing and the numbering is not continuous.

4.1.14.2 Alarm Actuation Function

Independently of the alarm indication function you can set alarm actuation function for some of the nonstandard conditions. Actuation means intervention in the regulation process, especially interruption of controller's operation, usually with subsequent disconnection of regulation sections. See list of actuations in table 6.

table 6: Alarm – actuation

#	condition	description	minimum delay activation / deact.	actuation
1	undercurrent	current at C.T.'s secondary under minimum measurement current	10 / 5 seconds	disconnection of all sections except fixed ones
4	voltage failure	measurement voltage not detected	5 / 5 seconds	disconnection of all sections except fixed ones
5	harmonic distortion	CHL limit setting exceeded (Novar 5+ only)	1 / 1 minute	disconnection of all sections
7	overvoltage	measurement voltage over 110 % of nominal value (230/115 V AC)	1 / 1 minute	disconnection of all sections
8	feeding back	power flow from appliance to source detected	5 / 2.5 minutes	disconnection of all sections except fixed ones
9	section error	permanently wrong section value detected in regulation (usually section failure)	5 connections + 5 disconnections	section disablement (see description in chapter below)

Note: Bold type conditions above are set by default.

If you require that the controller respond to occurrence of an above nonstandard condition with an actuation shown, you have to set the condition of choice in the side branch of parameter 30 to **A** or **2** (see previous chapter).

Conditions not shown in this table do not trigger any actuations, hence they can not be set this way either.

4.1.15 Parameter 31 – Capacitor Harmonic Load (CHL) Limit for Alarm Indication or Actuation

If alarm indication or actuation function is set from condition 5 (voltage harmonic distortion), you also have to specify the CHL limit level from which the indication or actuation should be triggered.

4.1.15.1 Capacitor Harmonic Load factor

For reaching guaranteed lifetime of compensation capacitors, exceeding of maximum limit values should be avoided. One of the limits is maximal available current. If voltage harmonic distortion occurs, due to impedance of capacitor decreases with frequency maximal available capacitor current can be exceeded.

If voltage is not distorted (sinus), capacitor current is

$$I_c = \frac{U}{Z_c} = \frac{U}{1/2\pi f C} = 2\pi f C U \quad [A] \quad [1]$$

where :

I_c ...capacitor current	[A]
U ...capacitor voltage	[V]
Z_c ...capacitor impedance	[Ω]
f ... frequency	[Hz]
C ...capacity of capacitor	[F]

If voltage is distorted, the current flowing through capacitor is created as vector sum of current harmonic components

$$\vec{I}_c = \sum_{i=1}^n \vec{I}_i \quad [A] \quad [2]$$

and magnitude of each harmonic component is according formula [1]

$$I_i = 2 \pi f_i C U_i = 2 \pi (f_f \times i) C U_i \quad [A] \quad [3]$$

where :

i ...harmonic order	[-]
I_i ...current of i^{th} harmonic component	[A]
U_i ...voltage of i^{th} harmonic component	[V]
f_i ...frequency of i^{th} harmonic component	[Hz]
f_f ... fundamental harmonic frequency	[Hz]

According formula [3] magnitude of current of each harmonic component is proportional to multiple of voltage and its order ($U_i \times i$). Consequently, total harmonic distortion defined as

$$THD_U = \sqrt{\sum_{i=2}^N \left(\frac{U_i}{U_1} \right)^2} \quad [\%] \quad [4]$$

where :

THD_U...total harmonic distortion of voltage [%]

U_i.....voltage of ith harmonic component [V]

U₁.....voltage of fundamental harmonic component [V]

is not suitable as criterion of capacitor current overload due to harmonic distortion, because it doesn't contain information of spectral layout.

Therefore we define capacitor harmonic load factor

$$CHL = \sqrt{\sum_{i=1}^N \left(\frac{iU_i}{U_{NOM}} \right)^2} * 100 \quad [\%] \quad [5]$$

where :

CHL...capacitor harmonic load factor [%]

i.....harmonic order [-]

U_i.....voltage of ith harmonic component [V]

U_{NOM}...nominal voltage [V]

This factor value depends not only on harmonic component magnitudes, but on spectral layout of all ones and voltage as well. Therefore it is more useful as value representing current harmonic load of capacitor. When undistorted voltage of nominal level its value is 100 %.

When setting harmonic distortion alarm function, you also have to specify the CHL limit level (parameter 31) from which the indication or actuation should be triggered. The parameter is shown as percentage and it can be set in the range from 80 to 300 %.

Following table shows several examples of harmonic distortion layout and appropriate CHL value for nominal voltage of fundamental harmonic component.

Tab. 7 : CHL factor examples for various voltage harmonic distortion layouts ($U_1=U_{NOM}$)

No.	voltage harmonic component levels [%]									CHL [%]
	3.	5.	7.	9.	11.	13.	15.	17.	19.	
1	2.5	3.5	2.5	1.0	2.0	1.5	0.8	1.0	0.5	110
2	3.5	4.5	3.5	1.2	2.5	2.0	1.0	1.5	1.0	118
3	5.0	6.0	5.0	1.5	3.5	3.0	0.5	2.0	1.5	133
4	5.5	6.5	5.5	2.0	4.0	4.0	1.8	2.3	1.8	146
5	8.0	9.0	8.0	6.0	7.0	7.0	2.3	4.0	3.5	208

Example No. 3 (CHL = 133 %) corresponds with maximal admissible levels of voltage harmonic distortion as specified in EN 50160 standard. Default preset value of CHL limit is 130 %.

If neither indication nor actuation function from harmonic distortion condition has been set, the CHL limit value is not shown.

4.1.16 Parameter 32 – Number of Switching Operations Limit for Alarm Indication or Actuation

If alarm indication or actuation function is set from condition 6 (number of switching operations exceeded), you also have to specify limit number of connections and disconnection of a section from which the indication or actuation should be triggered.

Number of switching operations limit (parameter 32) is shown as thousands of switching operations and it can be set in the range from 10 thousand to 2 million switching operations.

If neither indication nor actuation function from either of the two conditions has been set, the corresponding limit value is not shown.

4.1.17 Parameter 40 – Alarm Status

If indication function from a nonstandard condition is set (see description of parameter 30 – alarm setting), you can view alarm current status in the side branch of parameter 40.

Indication can be triggered by any of the nine conditions shown in table 5. Parameter 40 is used for detailed identification of condition that has triggered alarm indication. Alarm indication function has been triggered by those conditions whose value is *1*.

4.1.18 Parameters 41, 42, 43 – Extreme Mains Parameters Recorded

In order to monitor and analyze the regulation process, the controller Novar 5+ records the following extreme mains parameters:

- minimum power factor (parameter 41)
- maximum level of capacitor harmonic load factor (CHL, parameter 42)
- maximum level of selected voltage harmonic components (3rd, 5th, 7th, 11th, 13th, 17th – side branch of parameter 43)

These values are not specified in a controller when shipped so when viewing the parameters you will see ----. After the regulation process has started, the controller monitors the levels of the above mentioned quantities and if they reach a level which is lower or higher than a level so far recorded and such a condition holds for at least 1 minute, it will overwrite the last recorded extreme value with the newly measured value.

Minimum power factor (parameter 41) is processed while the regulation process is in progress and if the total load in the mains reaches at least 10 % of the nominal load only (in accordance with the metering current transformer's nominal primary value). If load is low, the value of the minimum power factor can neither be measured precisely, nor are they important.

Each extreme level recorded can be reset by editing it.

4.1.19 Parameter 44 – Number of Section Connections and Disconnections

In the side branch of this parameter you can check the number of switching operations for each section. The number is shown in thousands. If the number of switching operations is low, the value is

shown with a decimal point so that you can view it at accuracy down to units, tens or hundreds of switching operations.

The number of section connections and disconnections is kept in the controller's nonbacked up memory and stored in backed up memory about every eight hours where it is maintained even on power supply outage. The number of switching operations from the last eight-hour interval is lost on voltage failure or controller initialization.

If a section's circuit breaker is replaced, the relevant output's switching operation counter can be reset by editing it.

4.1.20 Parameter 46 – Regulation Time

When optimizing controller parameter settings, it is sometimes required to monitor regulation time in detail. You can view the regulation time's current value in this parameter – it is shown in seconds as countdown to the next regulation intervention.

For monitoring the regulation time to make sense, the regulation function must not be halted — therefore the regulation function is enabled while viewing this very parameter. Another difference while viewing this parameter is automatic jump back to display of values measured; this automatic jump takes only place after viewing the regulation time for about 5 minutes from the last button pressing (it takes place as soon as after about 30 seconds while viewing any other parameters).

4.2 Section Value Accurization

If the controller is set to automatic sectional current detection, it will carry out the automatic detection process after every power supply outage or initialization.

After successful completion of the automatic recognition process it records all the currents measured and start regulation process. All currents measured are tagged as “not yet precise”. A sections the value of which is not yet precise can be identified by **slowly** flashing decimal point (as opposed to fast flashing decimal point to identify a disabled section – see description further below).

The controller measures the sections continually within the regulation process as they are connected and disconnected. It evaluates the average value measured for each not-yet-precise section and, when having received about 100 values, it rewrites the original section value, which was obtained in automatic detection, with it. At the same time it tags the section as “precise” and stops further accurization of this section.

This way possible inaccuracies in automatic detection are removed.

If the sections' values are set manually (using the switching program and smallest capacitor current or by editing section value in parameter 25), no subsequent accurization takes place.

If automatic sectional current detection is enabled, the accurization process can be automatically started anytime during the regulation process as well. If the controller detects that a compensation capacitor has repeatedly been showing a value different from that measured in automatic detection and the difference is not in order of magnitude (that is in the interval from a half to double value) from the value recorded in the controller, the accurization process for such a section will start. Thus effects of changes in compensation capacitor values, for example as a consequence of the forming process after installation or due to aging etc., can be eliminated.

4.3 Faulty Section Indication and Disablement

In the alarm setting (parameter 30) you can choose alarm indication or actuation function from faulty section detection (section error).

If at least one of these functions has been set, the controller continually checks reactive current changes in the mains during the regulation process as the sections are connected and disconnected and compares them with each section's current recorded. If connecting and disconnecting a section does not repeatedly result in adequate change in reactive current in the mains (or change in reactive current measured is very different from the capacitor's value recorded), the controller tags such a section as faulty and, if a relevant alarm actuation function has been set, it will disable the section and stop using it in further regulation temporarily.

Alarm indication function can be used for section disablement indication (see description of parameter 30). If alarm actuation function is not set, the controller will only tag the faulty section, trigger alarm indication, but will keep using the section in regulation. A particular faulty section can be identified by **fast** flashing (about three times a second) decimal point in the section value display in the side branch of parameter 25 (as opposed to slowly flashing decimal point identifying not-yet-precise section – see description in chapter above).

A section that has been temporarily disabled is periodically, about every five days, checked by including it in regulation for one switching operation. If the controller detects a relevant response in the mains (within adequate allowance) to connecting the section, it will include the section in the regulation process again and, if automatic section detection is set, it will run accurization process for it too. This way, for example, a repaired section is automatically included in regulation (after replacing section fuse, for instance).

If the controller does not put a disabled section back to regulation automatically, such reinclusion in the regulation process will take place in the following situations:

- power supply interruption or controller initialization (see description further below)
- editing the section's value or one of parameters 21 through 23 (switching program, smallest capacitor value, number of capacitors).
- automatic sectional current detection process

4.4 Regulation Interruption

If the controller is in the regulation mode (not in the **Manual** mode), one of the values measured, **COS**, **A** (I_{eff}) or **V** (U_{eff}), is shown on the numeric display and the controller carries out regulation process based on the values measured and parameter settings.

If you switch to display any of parameters (by the \uparrow , \downarrow buttons), all of the **COS**, **A** and **V** LEDs will get dark and the regulation process will be interrupted. Output relays will stay in the state they were at the moment of switching the display. The controller assumes the operator wants to check or change some of the parameters and it does not change the state of outputs until this is finished (provided no nonstandard conditions, such as measurement voltage failure, have occurred, of course). At the moment the operator switches back to one of instantaneous values display, the instrument continues the regulation process.

If the operator did not switch back to the instantaneous values display (power factor or current), the controller would switch to it automatically in about thirty seconds from the last button being pressed.

An exception is showing regulation time (parameter 46) – in this case the regulation interrupted will resume for operator to be able to check control process operation. Automatic switch to the instantaneous values display will occur after about 5 minutes.

Analogously to regulation interruption, automatic connection or sectional current detection process will be interrupted by the above mentioned procedure if in progress. It, however, starts over from the beginning again when resumed.

4.5 Manual Mode

When installing or testing the controller it may sometimes be required to check the function of each compensation section or it is necessary to put the automatic regulation process out of operation for a longer time.

In such situations you can switch the controller to a mode in which it only carries out measurements and displays the values. You can switch to this mode by pressing buttons \uparrow and \downarrow and holding them down simultaneously for about 6 seconds (until the **Man.** LED starts flashing). You can switch back to the regulation mode analogously.

You **can not** view or edit the controller's parameters in the **Manual** mode – you can only switch on or off each controller's output.

On switching the regulator to the **Manual** mode, the outputs stay in the state they were in during the regulation process before switching over the modes. You can then change the states of the outputs manually – the state of any output can be listed using buttons \uparrow and \downarrow (for example **1-0**, which means output 1 is off – contacts open) and you can move through them and edit them analogously with the instruments' parameters. The outputs' states change while being edited while respecting the reconnection delay time set.

If the controller is in the **Manual** mode and there is a measurement voltage failure, the **Manual** mode is resumed on power recovery. At this all outputs that were on before the failure get switched on one by one again (the states of outputs are remembered).

4.6 Manual Intervention in Regulation Process

In order to be able to check the controller's response to a regulation deviation change it is possible to connect or disconnect a section by operator's manual intervention, not only in the **Manual** mode but also within the regulation process.

While holding button **ENTER** pressed down you can connect or disconnect section using buttons \uparrow and \downarrow and watch the controller's response to the change of condition. Each button press connects or disconnects one regulation section, always the one with the smallest value. Reconnection delay time is respected when connecting.

If the controller is left in the regulation mode, it will carry out evaluation and regulation intervention after the regulation time has elapsed thus putting the unbalanced conditions in the mains back to a compensated state.

4.7 Controller Initialization

In some situations it may be necessary to put the controller back in its default setting in which it is shipped. You can do this using controller *initialization*. After initialization has been run, the initial test starts too, that means the controller carries out all the operations as if the power supply voltage is introduced.

The controller's parameters are set to the values shown as default in table 1 on initialization, except the following parameters:

- type of measurement voltage (phase or line, 15)
- 6th relay function (alarm or control, 17)

These parameters remain unchanged in the values set before initialization.

The counter of switching operations (parameter 44) is not affected by initialization.

You can start the controller initialization by pressing buttons ↓, ↑ and **ENTER** simultaneously and holding them down for about 6 seconds. The controller will first disconnect all sections connected and run the initial test – that is when you can release the buttons. Then it will carry out initialization itself and since parameter 16 value is not defined, it will start the automatic connection detection process.

Warning!!! The **Manual** mode is terminated on initialization if active!!! The controller is always set to the regulation mode after initialization!!!

4.8 Summary of Text Messages

In the measurement value display mode a text message may appear in some situations instead of the instantaneous power factor value. table 8 shows a list of these messages.

table 8: summary of text messages

message	meaning	comment
<i>H04</i> <i>T5T</i> <i>N05</i> <i>1.B</i> <i>U=P</i> <i>6=A</i>	initial sequence after power up or initialization - type of controller - firmware version - measurement voltage type set (phase) - preset value of the 6 th relay function (alarm function, disconnected at active state)	controller carries out self-diagnostics
<i>U=0</i>	measurement voltage not present or its fundamental harmonic component lower than minimum value	controller in waiting mode
<i>I=0</i>	measurement current absent or lower than minimum value	controller in waiting mode
<i>APX</i>	automatic connection detection process in progress	process can have 1 to 7 steps
<i>P=0</i>	automatic connection detection process has failed and method of connection of measurement voltage and current (parameter 16) is not defined	automatic connection detection process will run again in about 15 minutes automatically or parameter 16 value can be entered manually
<i>ACX</i>	automatic sectional current recognition process in progress	process can have 3 or 6 steps; about 30-second dwell after three steps
<i>C=0</i>	no capacitors have been successfully detected in automatic section recognition process or, in manual section value specification mode (parameter 20), parameters 21 through 26 have not been set properly or all capacitive sections have been automatically disabled because of error (parameter 25) or they are set as fixed (parameter 26)	if automatic section recognition process is set, it will be automatically repeated in about 15 minutes or you can set values of parameters 21 through 26 manually

5. Wiring Example

Novar-5 - typical installation

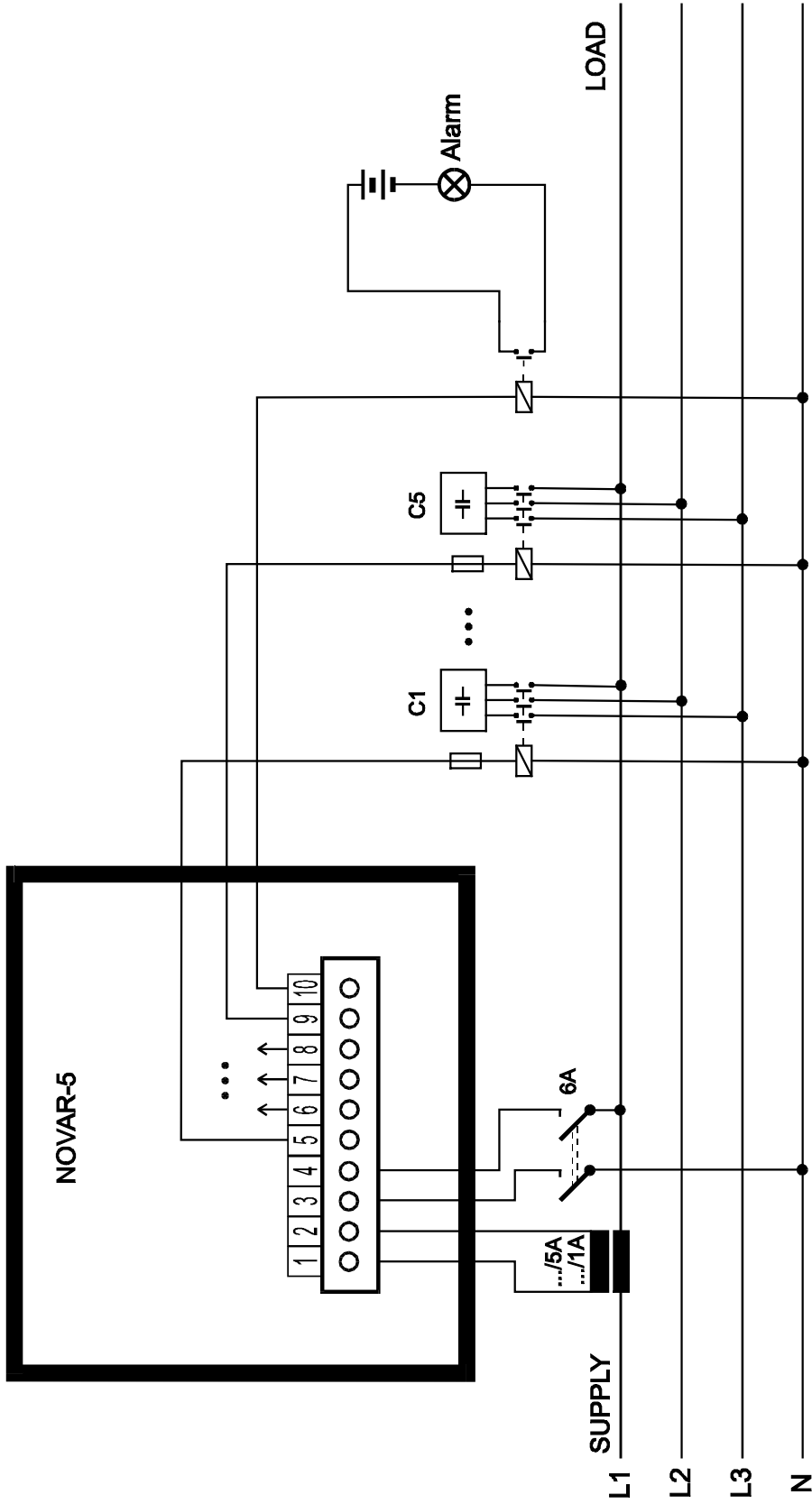

6. Technical Specifications:

adjustable parameters

target power factor	0.80 lag to 0.80 lead
switching time (maximum value, depends on regulation deviation)	5 to 1,200 seconds
delay time on reconnection	5 to 1,200 seconds
smallest capacitor current (C/k value calculated for metering current transformer primary side)	(0.05 ÷ 2 A) x metering current transformer ratio
method of setting compensation section values	automatic or manual
method of setting method of connection	automatic or manual

inputs–outputs

measurement current (galvanically isolated)	0.05 to 7.5 A
current input serial impedance	< 10 mΩ
current measurement accuracy	± 1 % ± 0.01 A
number of output relays	6
output relay load capacity	250 V AC / 4 A
power supply	230 V AC (115 V AC on request) , +10 / – 20 %, 50/60 Hz, max. 4 VA
installation overvoltage category	II as specified in EN 61010-1

operating conditions

Novar 5 :	operating environment operating temperature relative humidity	class B2 as specified in IEC 654-1 –5° ÷ +40° C 10 to 75 %
Novar 5+ :	operating environment operating temperature relative humidity	class C1 as specified in IEC 654-1 –40° ÷ +60° C 5 to 100 %

EMC

emission	EN 50081-2 EN 55011, class A (not for home use)
immunity	EN 61000-6-2
emission & immunity	EN 61326-1

physical features

sealing: - front panel - rear panel	IP40 (IP54 on request) IP 20
dimensions:	
- front panel	96 x 96 mm
- installation depth	80 mm
- installation panel cutout	92 x 92 mm
mass	maximum 0.4 kg

7. MAINTENANCE, TROUBLESHOOTING

Novar line power factor controllers do not require any maintenance within their operation. For reliable operation you only have to comply with the operating conditions specified and prevent mechanical damage to the instrument.

In case of the product's breakdown, you have to return it to the supplier at their address.

supplier:

manufacturer:

KMB systems, s.r.o.

559 Dr. M. Horákové

460 06, Liberec 7

Czech Republic

website: www.kmb.cz

The product must be packed properly to prevent damage in transit. Description of the problem or its symptoms must be sent along with the product. If warranty repair is claimed, the warranty certificate must be sent in too. If repair beyond warranty is required, a written order must be included.

Warranty Certificate

Warranty period of 24 months from the date of purchase, maximum 30 months from the date of dispatch from manufacturer's warehouse however, is provided for the instrument. Problems in the warranty period, provably because of faulty workmanship, design or inconvenient material, will be repaired free of charge by the manufacturer or an authorized servicing organization.

The warranty ceases even within the warranty period if the user makes unauthorized modifications or changes to the instrument, connects it to out-of-range quantities, if the instrument got damaged in out-of-specs falls or by improper handling or if it has been operated in contradiction with the technical specifications presented.

type of product: **NOVAR**..... serial number

date of dispatch: final quality inspection:

manufacturer's seal:

date of purchase: supplier's seal: